



S E R V I C E
E N T R A N C E
S P E C B O O K

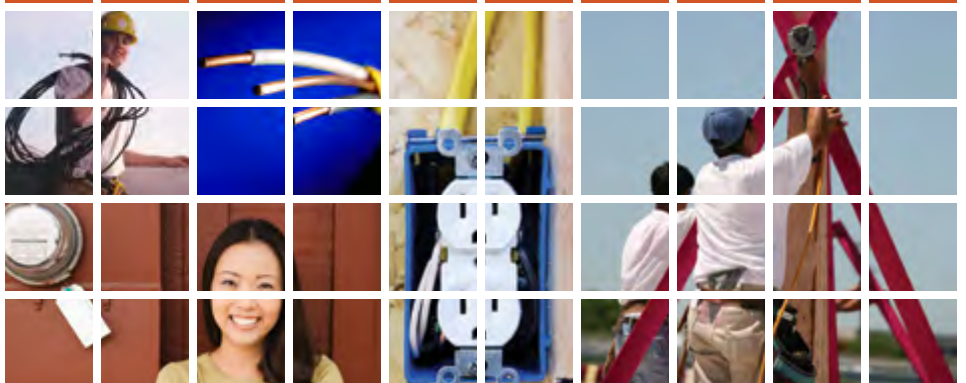



TABLE OF CONTENTS

MISSION STATEMENT	3
OFFICE HOURS	4
SERVICE ENTRANCE SPECIFICATIONS—GENERAL NOTES.....	5
PERMANENT OVERHEAD SERVICE - METER POLE	6-7
TEMPORARY OVERHEAD SERVICE - METER POLE	8-9
TEMPORARY UNDERGROUND SERVICE - METER POLE.....	10-11
PERMANENT OVERHEAD SERVICE - THRU ROOF (ROOF JACK).....	12-13
PERMANENT OVERHEAD SERVICE - WALL MOUNTED.....	14-15
PERMANENT UNDERGROUND SERVICE - WALL MOUNTED	16-17
PERMANENT UNDERGROUND SERVICE TO MOBILE HOME METER POLE	18-19
UNDERGROUND SERVICE.....	20-21
NET METERING REQUIREMENTS.....	22
OVERHEAD NET METER SPECIFICATIONS	23
UNDERGROUND NET METER SPECIFICATIONS.....	24
COMMERCIAL SERVICE ENTRANCE SPECIFICATIONS	25-28
SELF-CONTAINED POLY-PHASE METER DIAGRAMS	29-34
INSTRUMENT RATED METERING DIAGRAMS	35-38

OUR MISSION

DEMCO is focused on enhancing the quality of life for members by providing safe, reliable and competitively priced energy services.

24-Hour Outage & Emergency Service
1-844-MY-DEMCO (1-844-693-3626)

DEMCO.ORG

DEMCO MEMBER SERVICE CENTERS

OPEN:

Monday - Friday, 8am - 12pm & 1pm - 4:30pm Closed for lunch 12pm - 1pm
Drop box available at all district offices; payments transact on the next business day.

**DEMCO
HEADQUARTERS**
16262 Wax Road
Greenwell Springs, LA 70739

DENHAM SPRINGS

1810 Range Ave.
Denham Springs, LA 70726

ST. FRANCISVILLE

16843 LA Highway 61
St. Francisville, LA 70775

LIVINGSTON

29444 Frost Road
Livingston, LA 70754

GREENSBURG

6823 LA Highway 10
Greensburg, LA 70441

GALVEZ

15095 Highway 931
Gonzales, LA 70737

ZACHARY

20110 Plank Road
Zachary, LA 70791

DEMCO.org

1-844-MyDEMCO
(1-844-693-3626)

#1- Report Outage or Hazard
#2- Billing & Payment Info
#3- Start, Stop, Transfer Service/General Inquires

SERVICE ENTRANCE SPECIFICATIONS

GENERAL NOTES

1. All service entrances must meet the minimum requirements before being connected by DEMCO.
2. In Parishes, Cities and Towns where an electrical inspection is required, please contact the proper officials for their minimum requirements.
3. Items not specifically covered here shall be bound by the requirements set in the National Electrical Code (NEC) edition, adopted by the State of Louisiana.
4. In East Baton Rouge Parish, the ground wire is to be connected to the system neutral in the first disconnect enclosure (panel box or disconnect box).
5. For all residential and commercial services less than 600A, all meter loop material, except meter, to be furnished, installed and maintained by member. The meter pan is to be installed and maintained by member. All 600 AMP and larger services will be provided Meter, Meter Pan, CT Cabinet and CTs and these items will be maintained by DEMCO.
6. Mobile home installations are to remain if mobile home is moved.
7. For underground service, Member/Builder is responsible for furnishing and installing conduit (36" below grade) from the meter pan to a point 24" beyond any surface obstruction (present or planned). This includes patios, driveways, sidewalks, etc.
8. Where overhead service crosses an area subject to vehicle traffic, the pole must be tall enough to ensure that the clearance from the service to the ground is at least 15' - 6".
9. The temporary pole shall be located no more than 15' nor less than 5' from the edge of the utility servitude and as close to the DEMCO pole, transformer, or pedestal as possible.
10. No Member-owned equipment (including lights, meter loops, etc.) shall be allowed on DEMCO facilities.

METER PAN INFORMATION

The member/contractor will be responsible for supplying and installing a DEMCO approved meter pan. DEMCO has meter pans available for purchase.

General Guidelines for approved meter pans.

- UL listed.
- NEMA 3R rating (outdoor use)
- Constructed of galvanized steel.
- The connectors shall be rated for both copper and aluminum.
- The ringless type.
- Match the service requirements. (i.e., 200 A service requires a 200 A meter pan)
- A 320 Amp meter pan shall have a by-pass lever.
- An underground service must have a meter pan approved for underground (Minimum dimensions for 200 A underground pan 11"W x 15.5"H x 4.5"D)

Milbank, Anchor, Square D, and Landis & Gyr are the only approved manufacturers.

For questions regarding meter pans, contact DEMCO at 1-844-693-3626.

PERMANENT OVERHEAD SERVICE - METER POLE

SINGLE PHASE — 120/240V - 200 AMP OR LESS

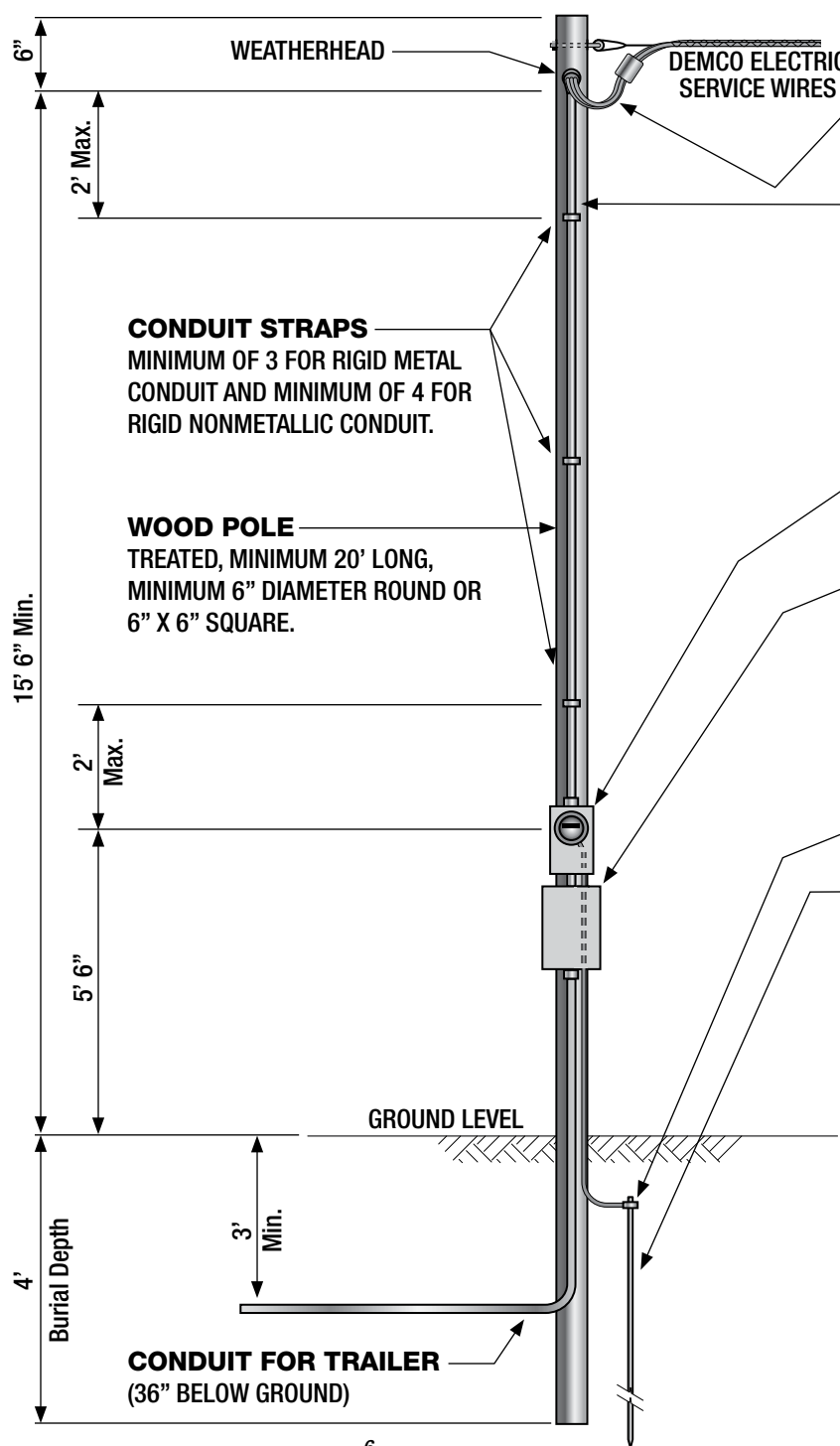

MEMBER'S WIRES

WIRES MUST BE INSULATED AND MUST EXTEND OUT OF THE WEATHERHEAD 18". WIRE SIZE MUST BE DETERMINED BY A QUALIFIED ELECTRICIAN. ACCEPTABLE WIRE SIZES FOR 100A SERVICES ARE #4 COPPER AND #2 ALUMINUM. ACCEPTABLE WIRE SIZES FOR 200A SERVICES ARE #2/0 COPPER AND #4/0 ALUMINUM.

CONDUIT

CONDUIT TO BE INSTALLED FROM THE WEATHERHEAD TO METER PAN TO DISCONNECT SWITCH. CONDUIT MAY BE RIGID METAL OR RIGID NONMETALLIC (SCHEDULE 80 PVC). CONDUIT SIZES MUST BE DETERMINED BY A QUALIFIED ELECTRICIAN. CONDUIT SIZES SMALLER THAN 2" ARE NOT ACCEPTABLE. USE SUITABLE COUPLINGS TO CONNECT CONDUIT TO METER PAN AND CONDUIT NIPPLE TO THE METER PAN AND DISCONNECT SWITCH.

METER PAN

DEMCO APPROVED METER PAN INSTALLED BY MEMBER. CONDUIT NIPPLE ATTACHED TO METER PAN MUST HAVE BUSHING. BOND NEUTRAL TO METER ENCLOSURE. SEE DETAIL "A".

DISCONNECT SWITCH (WEATHER PROOF)

FUSE OR BREAKER TYPE SUITABLE FOR SERVICE ENTRANCE. DISCONNECT SWITCH MUST BE SIZED BY A QUALIFIED ELECTRICIAN. BOND NEUTRAL TO DISCONNECT ENCLOSURE.

GROUND WIRE

#6 COPPER MINIMUM. PUT STAPLES EVERY 6 INCHES. GROUND WIRE MUST BE BONDED TO NEUTRAL LUG.

GROUND ROD CLAMP

USE CLAMP APPROVED FOR DIRECT BURIAL.

GROUND ROD

COPPER WELD OR GALVANIZED GROUND ROD NOT LESS THAN 8 FEET LONG AND NOT SMALLER THAN 5/8 INCH IN DIAMETER. BURY TOP OF GROUND ROD TO A DEPTH OF 1 FOOT.

NOTES:

1. ALL ITEMS SHOWN ARE MEMBER FURNISHED AND INSTALLED EXCEPT WHERE NOTED.
2. NO MEMBER FACILITIES WILL BE ALLOWED ON DEMCO FACILITIES.
3. WHERE LOCAL ORDINANCE PERMITS FACTORY INSTALLED POWER SUPPLY CORD WILL BE ALLOWED.

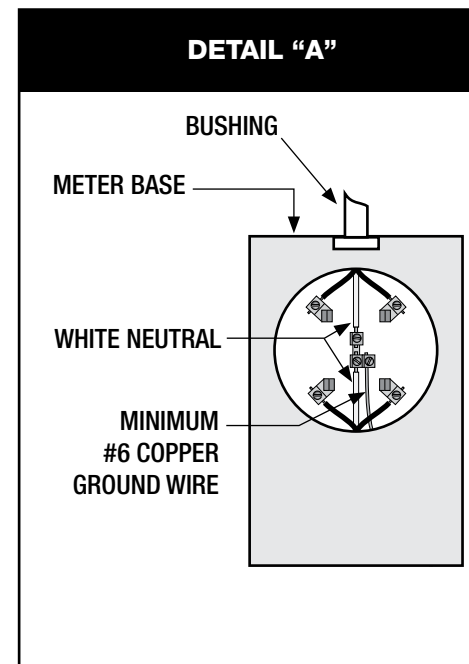

TEMPORARY OVERHEAD SERVICE - METER POLE

SINGLE PHASE — 120/240V — 200 AMP OR LESS

MEMBER'S WIRES

WIRES MUST BE INSULATED AND MUST EXTEND OUT OF THE WEATHERHEAD 18". WIRE SIZE MUST BE DETERMINED BY A QUALIFIED ELECTRICIAN.

WEATHERHEAD

12' MINIMUM HEIGHT. WHEN SERVICE WILL CROSS AN AREA SUBJECT TO VEHICLE TRAFFIC, THE MINIMUM HEIGHT SHALL BE 15' - 6".

CONDUIT

CONDUIT TO BE INSTALLED FROM THE WEATHERHEAD TO METER PAN TO DISCONNECT SWITCH. CONDUIT MAY BE RIGID METAL OR RIGID NONMETALLIC (SCHEDULE 80 PVC). CONDUIT SIZES MUST BE DETERMINED BY A QUALIFIED ELECTRICIAN. CONDUIT SIZES SMALLER THAN 1 1/4" ARE NOT ACCEPTABLE. USE SUITABLE COUPLINGS TO CONNECT CONDUIT TO METER PAN AND CONDUIT NIPPLE TO THE DISCONNECT SWITCH.

CONDUIT STRAPS

MINIMUM OF 3.

METER PAN

DEMCO APPROVED METER PAN INSTALLED BY MEMBER. CONDUIT NIPPLE INSIDE METER PAN MUST HAVE BUSHING. BOND NEUTRAL TO METER ENCLOSURE. SEE DETAIL "A".

DISCONNECT SWITCH (WEATHER PROOF)

FUSE OR BREAKER TYPE SUITABLE FOR SERVICE ENTRANCE. DISCONNECT SWITCH MUST BE SIZED BY A QUALIFIED ELECTRICIAN. BOND NEUTRAL TO DISCONNECT ENCLOSURE.

GROUND WIRE

#6 COPPER MINIMUM. PUT STAPLES EVERY 6 INCHES. GROUND WIRE MUST BE BONDED TO NEUTRAL LUG.

GROUND ROD CLAMP

USE CLAMP APPROVED FOR DIRECT BURIAL.

GROUND ROD

COPPER WELD OR GALVANIZED GROUND ROD NOT LESS THAN 8 FEET LONG AND NOT SMALLER THAN 5/8 INCH IN DIAMETER. GROUND ROD CAN BE EXTENDED 12" ABOVE FINISH GRADE FOR TEMPORARY INSTALLATION.

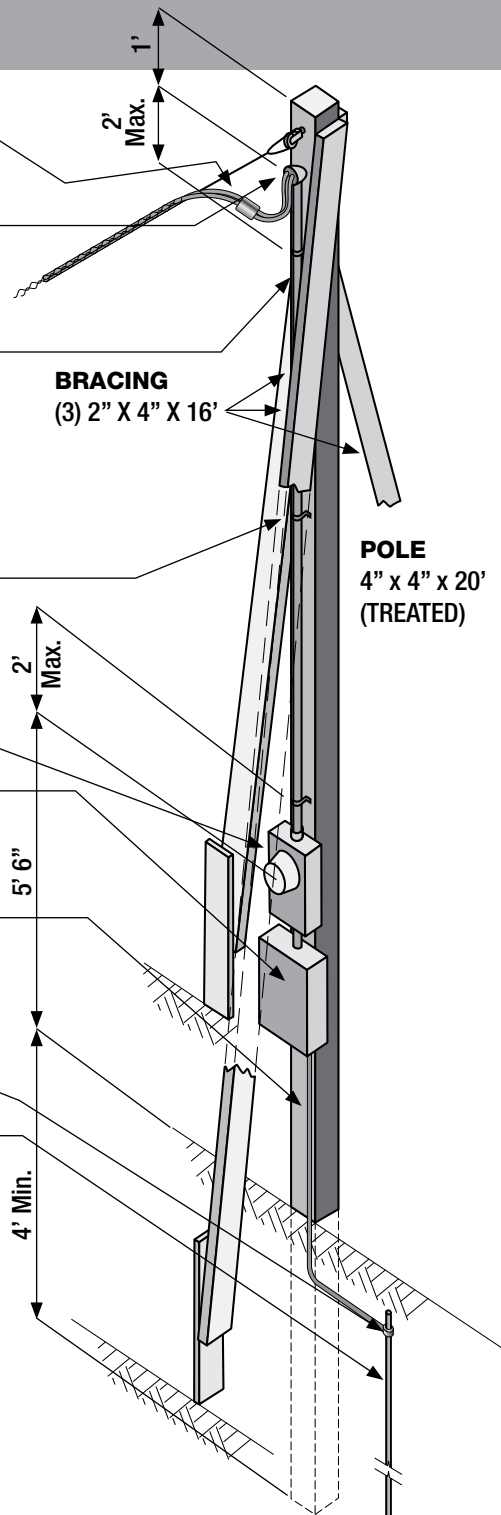

NOTES:

1. TEMPORARY SERVICE STRUCTURES SHALL WITHSTAND THE STRESSES OF SERVICE WIRES AND ATTACHED EQUIPMENT.
2. ANY TEMPORARY SERVICE THAT IS NOT CONSIDERED ADEQUATE SHALL NOT BE CONNECTED.
3. ALL SINGLE PHASE RECEPTACLE OUTLETS THAT ARE NOT A PART OF THE PERMANENT WIRING OF THE BUILDING OR STRUCTURE MUST HAVE GROUND-FAULT CIRCUIT INTERRUPTER PROTECTION.
4. MINIMUM OF 4' x 4' x 20' - 0" TREATED SERVICE POLE.
5. BRACING SHALL BE SET BACK A MINIMUM OF 6' FROM POLE.
6. ADDITIONAL BRACING WILL BE REQUIRED FOR DISTANCES FURTHER THAN 30' FROM UTILITY POLE.
7. ALL ITEMS SHOWN ARE MEMBER FURNISHED AND INSTALLED EXCEPT WHERE NOTED.
8. NO MEMBER FACILITIES WILL BE ALLOWED ON DEMCO FACILITIES.

DETAIL "A"

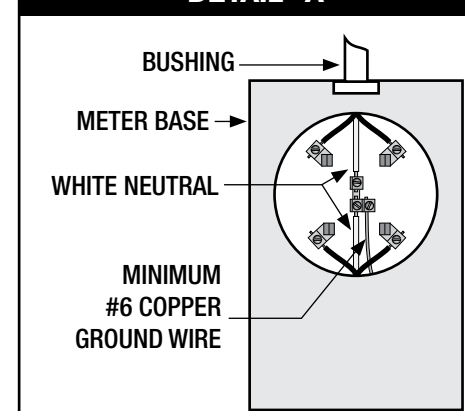

TEMPORARY UNDERGROUND SERVICE - METER POLE

SINGLE PHASE — 120/240V — 200 AMP OR LESS

METER PAN

DEMCO APPROVED METER PAN INSTALLED BY MEMBER. CONDUIT NIPPLE INSIDE METER PAN MUST HAVE BUSHING. BOND NEUTRAL TO METER ENCLOSURE. SEE DETAIL "A".

CONDUIT

CONDUIT MUST BE RIGID NONMETALLIC (SCHEDULE 80 PVC). CONDUIT SIZES MUST BE DETERMINED BY A QUALIFIED ELECTRICIAN. CONDUIT SIZES SMALLER THAN 1 1/4" ARE NOT ACCEPTABLE. USE SUITABLE COUPLINGS TO CONNECT CONDUIT TO METER PAN AND CONDUIT NIPPLE TO THE DISCONNECT SWITCH. CONDUIT TO BE INSTALLED FROM THE METER PAN TO A MINIMUM OF 24" BELOW GRADE AND FROM THE METER PAN TO THE DISCONNECT SWITCH. EXTEND DIRECT BURIAL CABLE FROM THE METER PAN THROUGH CONDUIT AND BACK ABOVE GRADE. ALLOW FOR SUFFICIENT WIRE TO REACH SOURCE.

DISCONNECT SWITCH (WEATHER PROOF)

FUSE OR BREAKER TYPE SUITABLE FOR SERVICE ENTRANCE. DISCONNECT SWITCH MUST BE SIZED BY A QUALIFIED ELECTRICIAN. BOND NEUTRAL TO DISCONNECT ENCLOSURE.

GROUND WIRE

#6 COPPER MINIMUM. PUT STAPLES EVERY 6 INCHES. GROUND WIRE MUST BE BONDED TO NEUTRAL LUG.

GROUND ROD CLAMP

USE CLAMP APPROVED FOR DIRECT BURIAL.

GROUND ROD

COPPER WELD OR GALVANIZED GROUND ROD NOT LESS THAN 8 FEET LONG AND NOT SMALLER THAN 5/8 INCH IN DIAMETER. GROUND ROD CAN BE EXTENDED 12" ABOVE FINISH GRADE FOR TEMPORARY INSTALLATION.

NOTES:

1. TEMPORARY SERVICE STRUCTURES SHALL WITHSTAND THE STRESSES OF SERVICE WIRES AND ATTACHED EQUIPMENT.
2. ANY TEMPORARY SERVICE THAT IS NOT CONSIDERED ADEQUATE SHALL NOT BE CONNECTED.
3. ALL SINGLE PHASE RECEPTACLE OUTLETS THAT ARE NOT A PART OF THE PERMANENT WIRING OF THE BUILDING OR STRUCTURE MUST HAVE GROUND-FAULT CIRCUIT INTERRUPTER PROTECTION.
4. THE TEMPORARY POLE SHALL BE LOCATED NO MORE THAN 15' NOR LESS THAN 5' FROM THE EDGE OF THE UTILITY SERVITUDE AND AS CLOSE TO THE DEMCO POLE, TRANSFORMER OR PEDESTAL AS POSSIBLE.
5. ALL ITEMS SHOWN ARE MEMBER FURNISHED AND INSTALLED EXCEPT WHERE NOTED.
6. NO MEMBER FACILITIES WILL BE ALLOWED ON DEMCO FACILITIES.

ALLOW FOR SUFFICIENT WIRE TO REACH SOURCE

CONDUIT STRAP

POLE
4" x 4"
(TREATED)

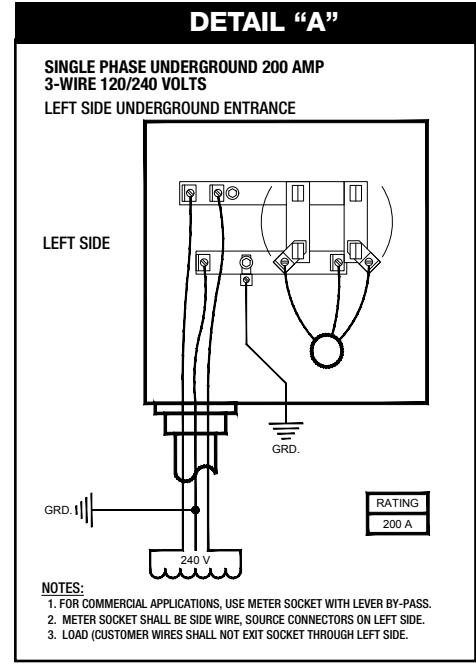
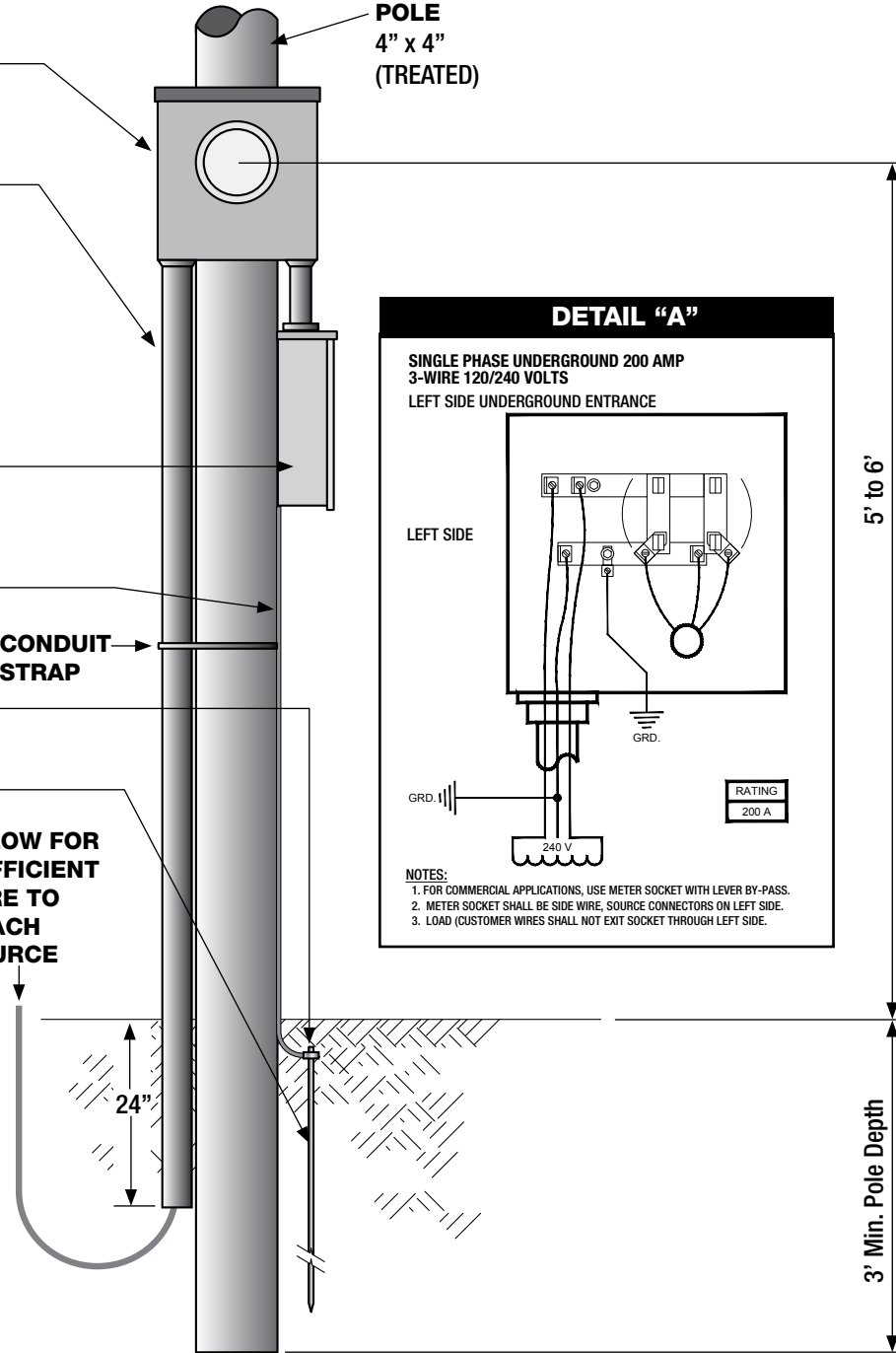

PERMANENT OVERHEAD SERVICE - THRU-ROOF (ROOF JACK)

SINGLE PHASE — 120/240V — 200 AMP OR LESS

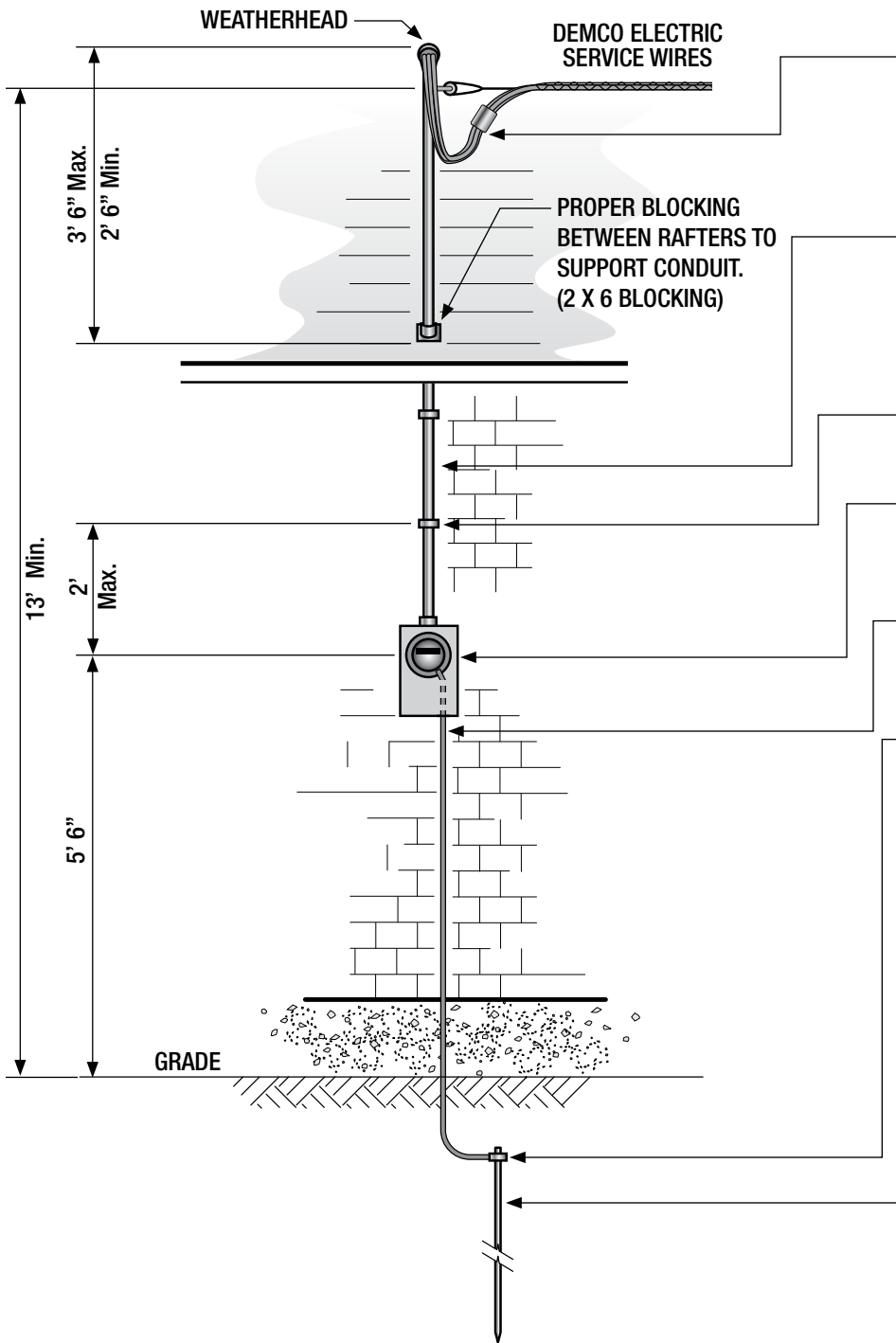

MEMBER'S WIRES

WIRES MUST BE INSULATED AND MUST EXTEND OUT OF THE WEATHERHEAD 18". WIRE SIZE MUST BE DETERMINED BY A QUALIFIED ELECTRICIAN. ACCEPTABLE WIRE SIZES FOR 100A SERVICES ARE #4 COPPER AND #2 ALUMINUM. ACCEPTABLE WIRE SIZES FOR 200A SERVICES ARE #2/0 COPPER AND #4/0 ALUMINUM.

CONDUIT

CONDUIT TO BE INSTALLED FROM THE WEATHERHEAD TO THE METER PAN. CONDUIT SHALL BE RIGID METAL. CONDUIT SIZES MUST BE DETERMINED BY A QUALIFIED ELECTRICIAN. CONDUIT SIZES SMALLER THAN 2" ARE NOT ACCEPTABLE. USE SUITABLE COUPLINGS TO CONNECT CONDUIT TO METER PAN.

CONDUIT STRAPS

STRAPS MUST BE INSTALLED NO MORE THAN 5 FEET APART.

METER PAN

DEMCO APPROVED METER PAN INSTALLED BY MEMBER. CONDUIT NIPPLE ATTACHED TO METER PAN MUST HAVE BUSHING. BOND NEUTRAL TO METER ENCLOSURE. SEE DETAIL "A".

GROUND WIRE

#6 COPPER MINIMUM INSTALLED IN 1/2" CONDUIT SECURELY FASTENED TO WALL. CONDUIT MAY BE RIGID METAL OR RIGID NONMETALLIC (SCHEDULE 80 PVC).

GROUND CLAMP

USE CLAMP APPROVED FOR DIRECT BURIAL.

GROUND ROD

COPPER WELD OR GALVANIZED GROUND ROD NOT LESS THAN 8 FEET LONG AND NOT SMALLER THAN 5/8 INCH IN DIAMETER. BURY TOP OF GROUND ROD TO A DEPTH OF 1 FOOT.

NOTES:

1. ALL ITEMS SHOWN ARE MEMBER FURNISHED AND INSTALLED EXCEPT WHERE NOTED.
2. NO MEMBER FACILITIES WILL BE ALLOWED ON DEMCO FACILITIES.

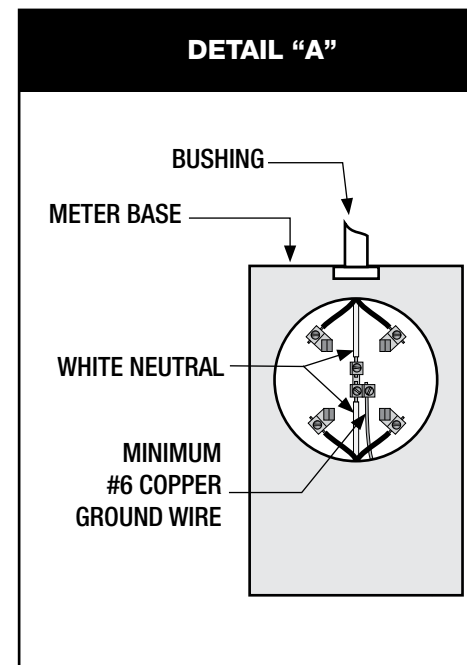

PERMANENT OVERHEAD SERVICE - WALL MOUNTED

SINGLE PHASE — 120/240V — 200 AMP OR LESS

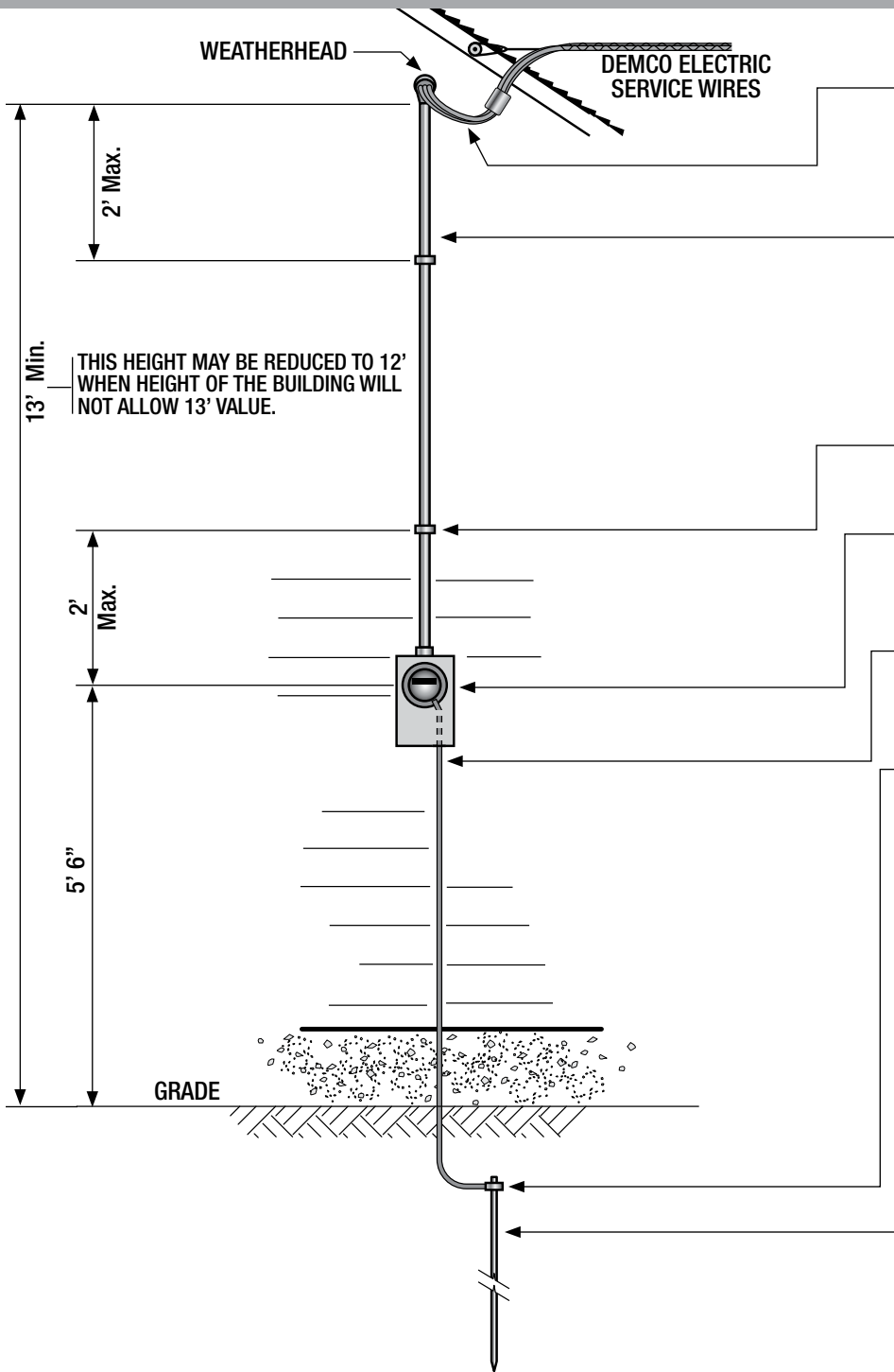

MEMBER'S WIRES

WIRES MUST BE INSULATED AND MUST EXTEND OUT OF THE WEATHERHEAD 18". WIRE SIZE MUST BE DETERMINED BY A QUALIFIED ELECTRICIAN. ACCEPTABLE WIRE SIZES FOR 100A SERVICES ARE #4 COPPER AND #2 ALUMINUM. ACCEPTABLE WIRE SIZES FOR 200A SERVICES ARE #2/0 COPPER AND #4/0 ALUMINUM.

CONDUIT

CONDUIT TO BE INSTALLED FROM THE WEATHERHEAD TO THE METER PAN. CONDUIT SHALL BE RIGID METAL. CONDUIT SIZES MUST BE DETERMINED BY A QUALIFIED ELECTRICIAN. CONDUIT SIZES SMALLER THAN 2" ARE NOT ACCEPTABLE. USE SUITABLE COUPLINGS TO CONNECT CONDUIT TO METER PAN.

CONDUIT STRAPS

STRAPS MUST BE INSTALLED NO MORE THAN 5 FEET APART.

METER PAN

DEMCO APPROVED METER PAN INSTALLED BY MEMBER. CONDUIT NIPPLE ATTACHED TO METER PAN MUST HAVE BUSHING. BOND NEUTRAL TO METER ENCLOSURE. SEE DETAIL "A".

GROUND WIRE

#6 COPPER MINIMUM INSTALLED IN 1/2" CONDUIT SECURELY FASTENED TO WALL. CONDUIT MAY BE RIGID METAL OR RIGID NONMETALLIC (SCHEDULE 80 PVC).

GROUND CLAMP

USE CLAMP APPROVED FOR DIRECT BURIAL.

GROUND ROD

COPPER WELD OR GALVANIZED GROUND ROD NOT LESS THAN 8 FEET LONG AND NOT SMALLER THAN 5/8 INCH IN DIAMETER. BURY TOP OF GROUND ROD TO A DEPTH OF 1 FOOT.

NOTES:

1. ALL ITEMS SHOWN ARE MEMBER FURNISHED AND INSTALLED EXCEPT WHERE NOTED.
2. NO MEMBER FACILITIES WILL BE ALLOWED ON DEMCO FACILITIES.

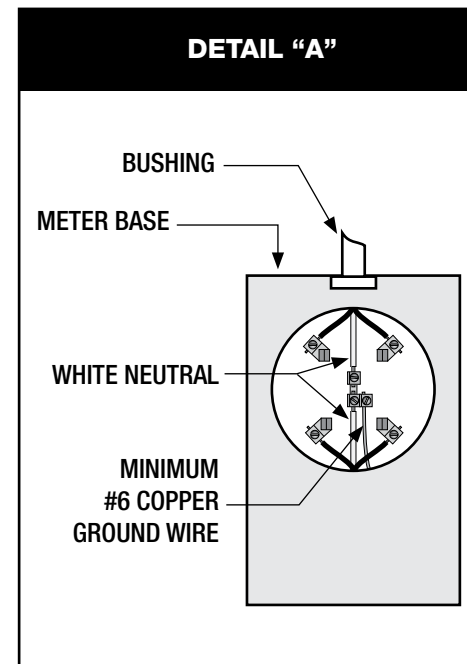

PERMANENT UNDERGROUND SERVICE - WALL MOUNTED

SINGLE PHASE — 120/240V — 200 AMP OR LESS

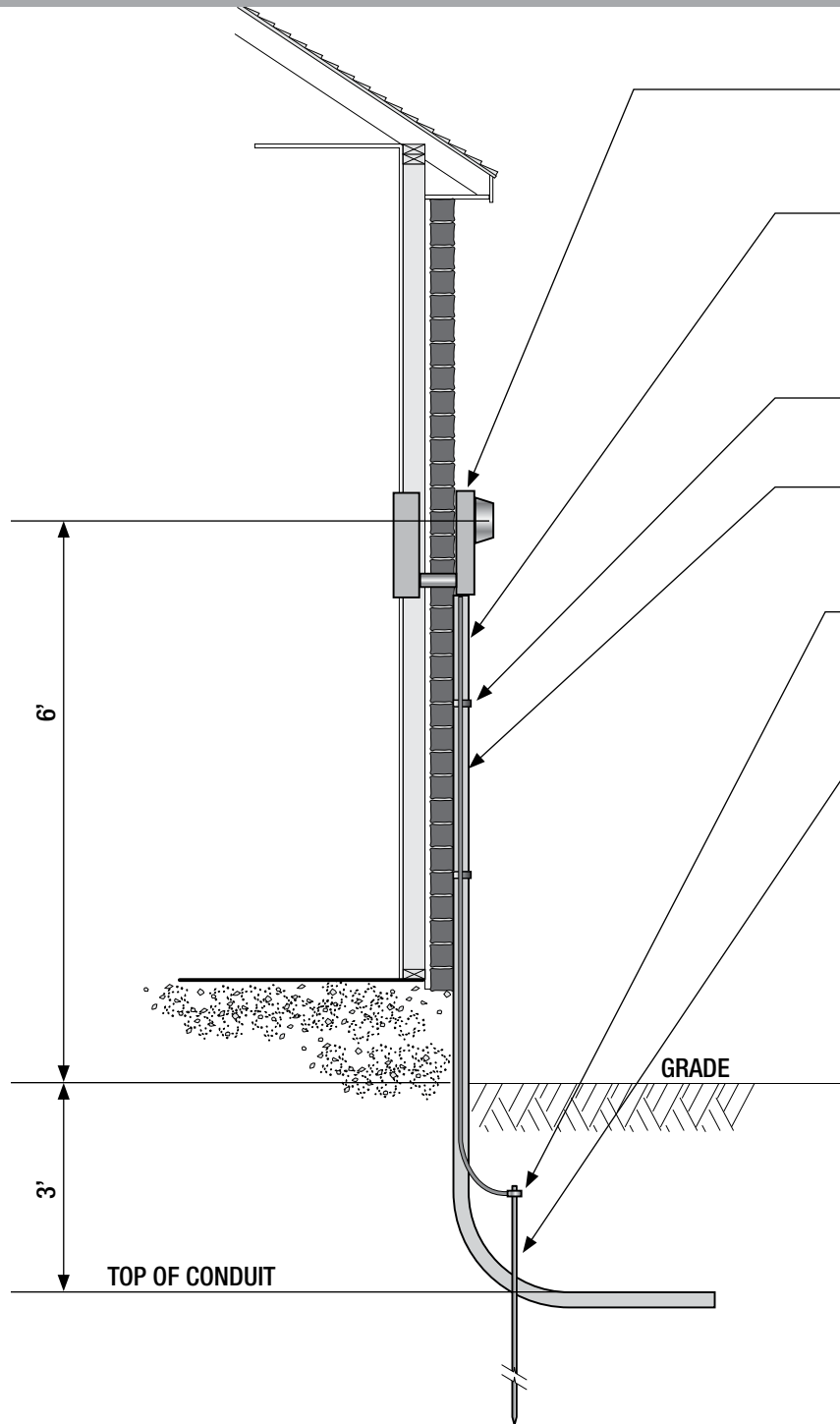

METER PAN

DEMCO APPROVED METER PAN INSTALLED BY MEMBER. CONDUIT NIPPLE ATTACHED TO METER PAN MUST HAVE BUSHING. BOND NEUTRAL TO METER ENCLOSURE. SEE DETAIL "A".

CONDUIT

CONDUIT MUST BE RIGID METAL OR RIGID NONMETALLIC (SCHEDULE 80 PVC). CONDUIT SIZES MUST BE DETERMINED BY A QUALIFIED ELECTRICIAN. CONDUIT SIZES SMALLER THAN 2.5" ARE NOT ACCEPTABLE. USE SUITABLE COUPLINGS TO CONNECT CONDUIT TO METER PAN. SEE NOTE 3.

CONDUIT STRAPS

MINIMUM 2.

GROUND WIRE

#6 COPPER MINIMUM INSTALLED IN 1/2" CONDUIT SECURELY FASTENED TO WALL. CONDUIT MAY BE RIGID METAL OR RIGID NONMETALLIC (SCHEDULE 80 PVC).

GROUND CLAMP

USE CLAMP APPROVED FOR DIRECT BURIAL.

GROUND ROD

COPPER WELD OR GALVANIZED GROUND ROD NOT LESS THAN 8 FEET LONG AND NOT SMALLER THAN 5/8 INCH IN DIAMETER. BURY TOP OF GROUND ROD TO A DEPTH OF 1 FOOT.

NOTES:

1. ALL ITEMS SHOWN ARE MEMBER FURNISHED AND INSTALLED EXCEPT WHERE NOTED.
2. 2" SCHEDULE 80 PVC CONDUIT SHALL BE PROVIDED BY MEMBER. CONDUIT FROM METER PAN SHALL EXTEND 24" (PATIOS, SIDEWALKS, DRIVEWAYS, ETC...)
3. CONDUIT TO BE INSTALLED FROM THE METER PAN TO 3' - 0" BELOW GRADE, UTILIZING (1) ONE 90° SWEEP, 24" RADIUS MINIMUM.
4. NO MEMBER FACILITIES WILL BE ALLOWED ON DEMCO FACILITIES.

DETAIL "A"

SINGLE PHASE UNDERGROUND 200 AMP
3-WIRE 120/240 VOLTS
LEFT SIDE UNDERGROUND ENTRANCE

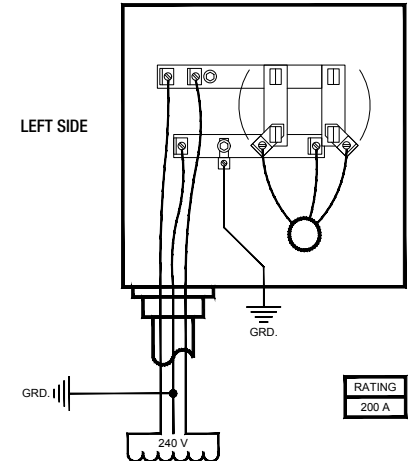

NOTES:

1. FOR COMMERCIAL APPLICATIONS, USE METER SOCKET WITH LEVER BY-PASS.
2. METER SOCKET SHALL BE SIDE WIRE, SOURCE CONNECTORS ON LEFT SIDE.
3. LOAD (CUSTOMER WIRES SHALL NOT EXIT SOCKET THROUGH LEFT SIDE.

PERMANENT UNDERGROUND SERVICE TO MOBILE HOME
METER POLE — UNDERGROUND SUBDIVISION
SINGLE PHASE — 120/240V — 200 AMP OR LESS

OPTION 1
SINGLE POLE MOUNT STRUCTURE

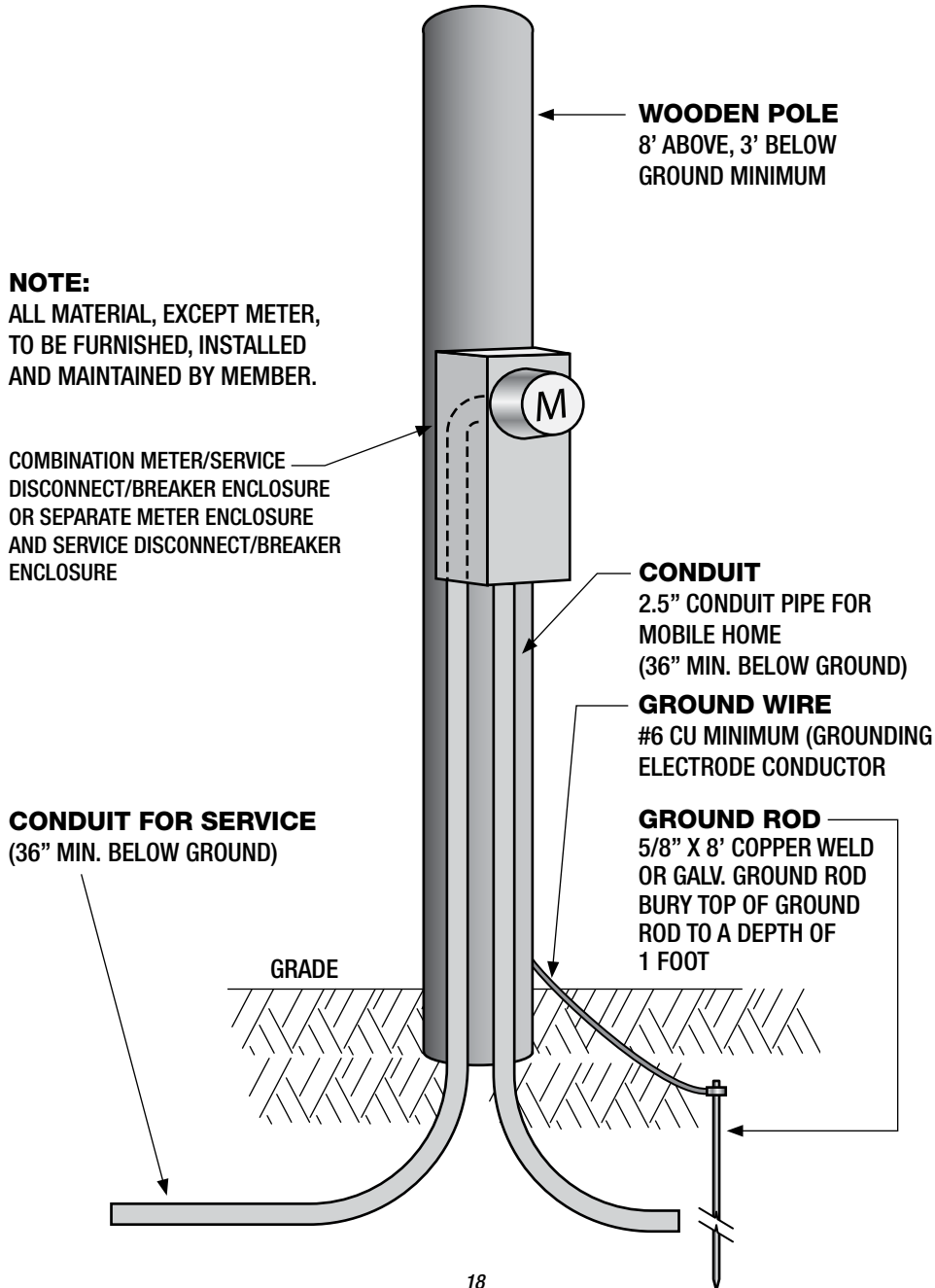

OPTION 2
TWO POLE MOUNT STRUCTURE

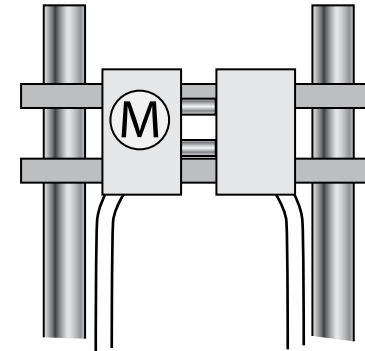

MOBILE HOME PANEL

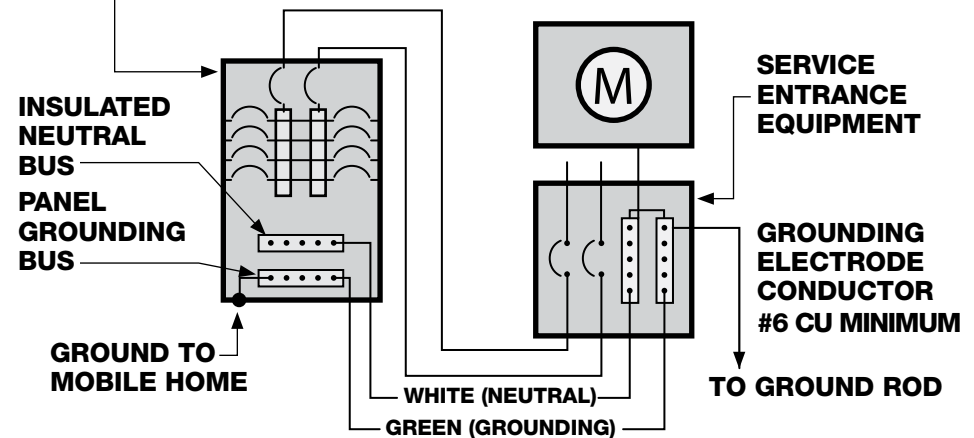

GROUNDING

THE WHITE (NEUTRAL) CONDUCTOR SHALL BE RUN FROM THE "INSULATED BUSBAR" IN THE MOBILE HOME PANEL TO THE SERVICE-ENTRANCE EQUIPMENT, WHERE IT IS CONNECTED TO THE TERMINAL AT THE POINT OF CONNECTION TO THE GROUNDING ELECTRODE CONDUCTOR.

THE GREEN-COLORED (GROUNDING) CONDUCTOR SHALL BE RUN FROM THE "PANEL GROUNDING BUS" IN THE MOBILE HOME TO THE SERVICE-ENTRANCE EQUIPMENT, WHERE IT IS CONNECTED TO THE WHITE CONDUCTOR (NEUTRAL) AT THE POINT OF CONNECTION TO THE GROUNDING ELECTRODE CONDUCTOR.

THE GROUNDED (WHITE) CONDUCTOR AND THE GROUNDING (GREEN) CONDUCTOR MUST BE KEPT SEPARATE WITHIN THE MOBILE HOME STRUCTURE IN ORDER TO SECURE THE MAXIMUM PROTECTION AGAINST ELECTRIC-SHOCK HAZARD SHOULD THE SUPPLY NEUTRAL CONDUCTOR BECOME OPEN.

UNDERGROUND SERVICE SINGLE RESIDENCE

PULL BOX FOR SECONDARY SYSTEM

Plastic or fiberglass for grass areas or polymer concrete for light duty areas
(see notes 2, 3, and 4)

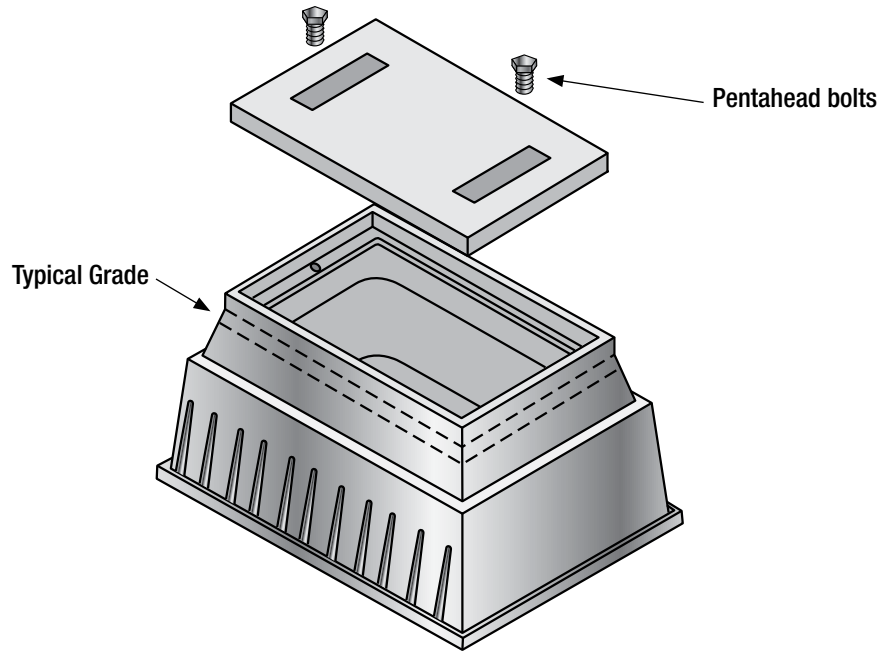

STANDARD SERVICE INSTALLATION WITH PULL BOX

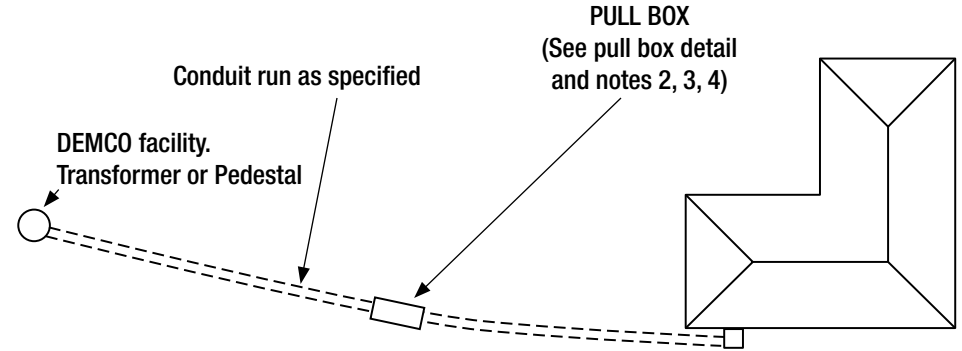

STANDARD SERVICE INSTALLATION

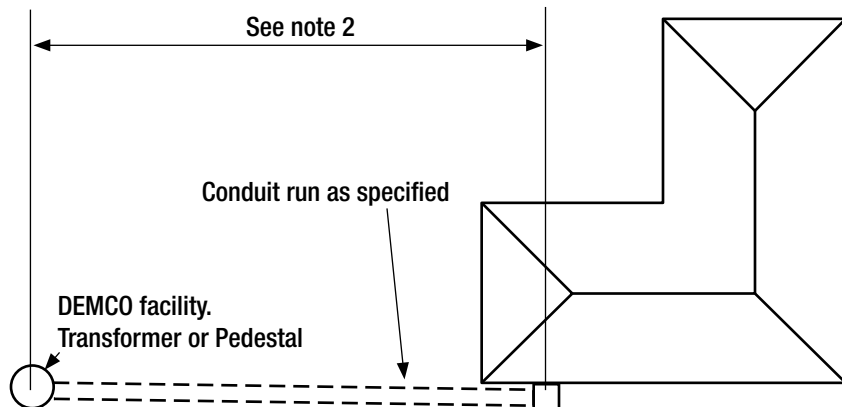

NOTES

1. MEMBER FACILITIES SHALL COMPLY WITH THE NEC AND AUTHORITIES HAVING JURISDICTION.
2. MEMBER SHALL CONSULT WITH COMPANY FOR LOCATION OF PULL BOX FOR ANY LENGTH OVER 200'.
3. IF MORE THAN THREE 90° BENDS (INCLUDING RISER BENDS AND REGARDLESS OF LENGTH) ARE REQUIRED IN ANY RUN, CONSULT THE COMPANY.
4. PULL BOX SHALL BE INSTALLED AT A 90° BEND OR THE CENTER OF RUN AND BE OF SUFFICIENT STRENGTH TO SUPPORT PROBABLE LOCAL TRAFFIC (CONSULT COMPANY FOR BOX IN AREAS WITH TRAFFIC OR TRUCKS DRIVING OVER BOXES). RECOMMENDED SIZE: 17"W X 30"L X 18"D.
5. THE MEMBER SHALL BEAR THE COST OF CONDUIT AND ITS INSTALLATION.
6. CONDUIT SHALL BE 2.5" AND SHALL BEAR THE U.L. LABEL, RIGID NON-METALLIC (SCHEDULE 80 PVC ABOVE THE GROUND, SCHEDULE 40 BELOW GRADE, GRAY ONLY.)
7. THE MEMBER SHALL INSTALL 80 lb. TEST NON-METALLIC (NYLON, ETC.) PULL LINE IN MEMBER'S CONDUIT.
8. UNDERGROUND SERVICE CONDUIT SHALL BE SEPARATED FROM TELEPHONE, CABLE, OR WATER FACILITIES BY NOT LESS THAN 3" OF CONCRETE, 4" OF BRICK MASONRY, OR 12" OF WELL TAMPED EARTH AND 18" OF WELL TAMPED EARTH FOR GAS FACILITIES.
9. CONDUIT TO BE INSTALLED TO THE SERVITUDE EDGE AT THE CLOSEST POINT TO DEMCO'S TRANSFORMER OR PEDESTAL.
10. CONDUIT SHALL BE INSTALLED AT A MINIMUM DEPTH OF 36" AND MUST BE INSPECTED BY A DEMCO REPRESENTATIVE BEFORE BACKFILLING.
11. MEMBER WILL BE REQUIRED TO CORRECT ANY PROBLEMS WITH CONDUIT PRIOR TO DEMCO INSTALLING WIRE. DEMCO WILL CORRECT PROBLEMS AT MEMBER'S REQUEST FOR AN ADDITIONAL FEE.

1. Member/Installer completes and submits the “**DEMCO Standard Interconnection Agreement for Net Metering Facilities**” application found on www.demco.org. The applicant has three options to return the form to DEMCO:
 - a. Scan and **email** the forms to eps@demco.org (directly to CSR group)
 - b. Snail **mail** the forms to **DEMCO P.O. Box 15659, Baton Rouge, LA 70895**
 - c. **Deliver** to any office (**Addresses on page 4**)
2. After permit clears, a DEMCO Serviceman will be routed to location for system inspection, test, and Net Meter conversion.
3. A \$100.00 fee applies.
4. **AC Disconnect Switch** must be **clearly labeled** as such, **ON the switch**, and as shown in the specifications that follow.

**SINGLE PHASE OVERHEAD 200 AMP
3-WIRE 120/240 VOLTS
FOR NET-METERING**

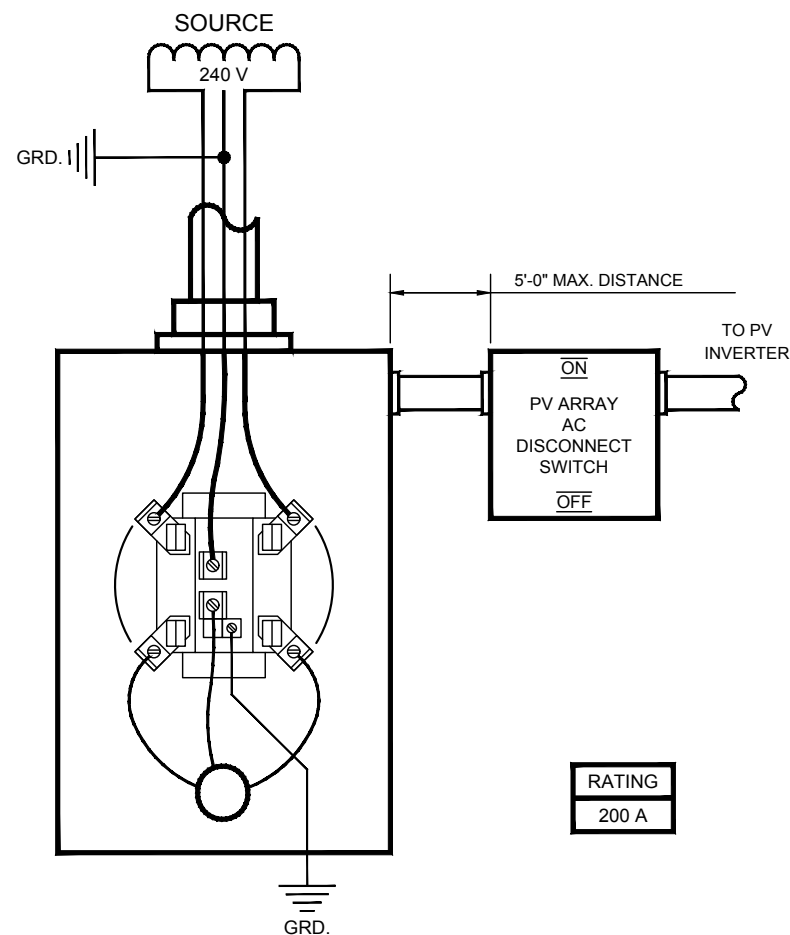

NOTES:

1. AC DISCONNECT SWITCH MUST BE CLEARLY LABELED AS SUCH AND BE LOCKABLE.

**SINGLE PHASE UNDERGROUND 200 AMP
3-WIRE 120/240 VOLTS
FOR NET-METERING**

LEFT SIDE UNDERGROUND ENTRANCE

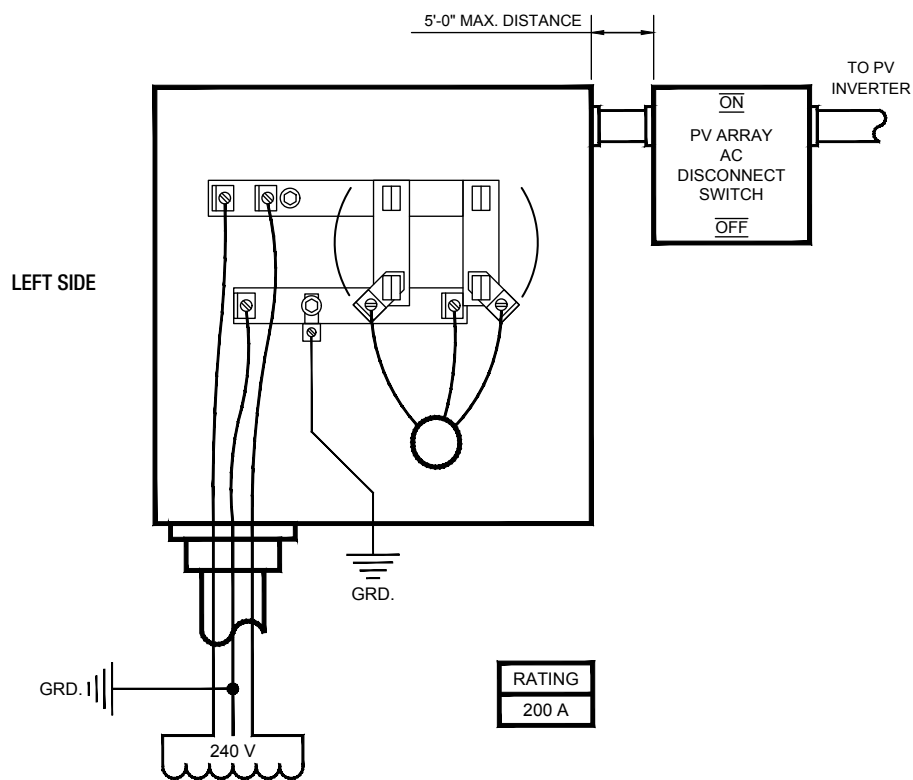

NOTES:

1. AC DISCONNECT SWITCH MUST BE CLEARLY LABELED AS SUCH AND BE LOCKABLE.
2. METER SOCKET SHALL BE SIDE WIRE, SOURCE CONNECTORS ON LEFT SIDE.
3. LOAD (CUSTOMER WIRES SHALL NOT EXIT SOCKET THROUGH LEFT SIDE.

480 VOLT LOAD BREAK DISCONNECT

For 277/480V, three-phase, four wire services 600A or less, The Member shall furnish and install a **non-fused load break disconnect switch, sized per NEC requirements**, on the source (DEMCO) side of each metering enclosure. This switch will be locked by DEMCO and shall only be operated by DEMCO personnel. A separate, properly sized overcurrent protective device shall be installed on the load side of the metering enclosure per NEC requirements and/or local codes. In all applications where multiple occupancies exist within a single premise, the Member is urged to utilize factory designed meter centers.

EXCEPTION: For individual 277/480V services exclusively served from a single transformer or transformer bank, and only with prior approval of the DEMCO engineering group, the transformer high-side disconnects may be the means used to de-energize the metering equipment. The high-side disconnects shall be operated only by DEMCO personnel and shall not be considered as the Member's service disconnecting means. The Member shall still be required to provide a service disconnecting means and overcurrent protection on the load (Member) side of the metering enclosure, per NEC requirements and/or local codes for these installations.

DISCONNECTING MEANS FOR SERVICE OVER 600 VOLTS:

The Member (Contractor, Developer, or Owner) shall provide a means of disconnecting all energized conductors of each service entrance from the source of supply. The disconnecting means shall comply with the requirements of the National Electrical Code and/or local codes.

The service disconnecting means shall simultaneously disconnect all ungrounded conductors and shall have a fault closing rating not less than the maximum short-circuit current available at its supply terminals.

When the Member's service equipment is located within a vault or consists of metal enclosed switchgear, the following types of over current protection will be allowed:

- (A) A non-automatic oil switch shall be permitted with fuses. The interrupting rating of this switch shall equal or exceed the continuous current rating of the fuse.
- (B) An automatic trip circuit breaker of suitable current carrying and interrupting capacity.
- (C) A switch capable of interrupting the no-load current of the Member's transformer and equipped with suitable fuses may be used provided the switch is interlocked with the secondary circuit breaker so that the switch cannot be opened when the circuit breaker is closed. Note: Metal-enclosed switchgear shall consist of a substantial metal structure and a sheet metal enclosure. Where installed over a combustible floor, suitable protection thereto shall be provided.

AUTOMATIC TRIP CIRCUIT BREAKER:

Where the Member's service equipment is not in a vault or metal enclosure, an automatic trip circuit breaker of suitable ampacity and interrupting capacity for over current protection is required. The circuit breaker shall be located outside the building as near as practicable to where the service conductors enter the building. The location shall be permitted on a pole, roof, foundation, or other structure. Where over current protective equipment is used as a disconnecting means, it shall simultaneously disconnect all ungrounded conductors and have a sufficient rating to interrupt the maximum available fault current at the Member's point of service.

MOTORS:

All motors served from DEMCO's facilities shall bear a manufacturer's nameplate indicating the voltage, current rating, speed, and horsepower rating for continuous and intermittent use. This nameplate shall also carry the NEMA "code letter" designation of the motor. When a motor is rewound to produce a change in its original design, a new nameplate shall be attached indicating the new characteristics and the name of the firm or person making the change.

It shall be the responsibility of the Member to consult with the Cooperative before installing any motor over twenty horsepower (20 hp) or any motor over 480 Volts. The Cooperative will determine the necessary requirements such as but not limited to "soft starting" that may be required.

Polyphase Motors - BTUH Rated:

For larger homes requiring heating and cooling capacity in excess of a nominal 50,000 BTUH, the Member should consult the Company to determine the type of service that will be supplied. The Member should not overlook the possibility of using two or more independent units which can provide better zone control.

MOTOR PROTECTION

Phase Reversal Protection:

Reverse phase relays are required on three-phase elevator services (National Electrical Code) and it is strongly recommended that they be installed by the Member where accidental reversal of motor rotation would cause serious inconvenience, damage, or delay.

Over-Current and Loss of Phase Protection:

It shall be the responsibility of the Member to provide thermal cutoff protection (reset manually type) on all single-phase motors and compressors being served from a three-phase transformer. It shall be the responsibility of the member to provide adequate over-current protection in each phase and to provide protection against the loss of a single phase on all motor installations. DEMCO assumes no liability for damages resulting from loss of phase in a three-phase service.

CAPACITORS AND OTHER REACTIVE EQUIPMENT:

The power factor should be held as close to unity as is possible. A low power factor results in the reduction of conductor and equipment capacities, thus reducing the overall efficiency of the electrical system. Where larger capacity motors are to be installed, consideration should be given to the use of synchronous type motors.

**THREE PHASE OVERHEAD 400 AMP
4-WIRE 277/480 VOLTS WYE**

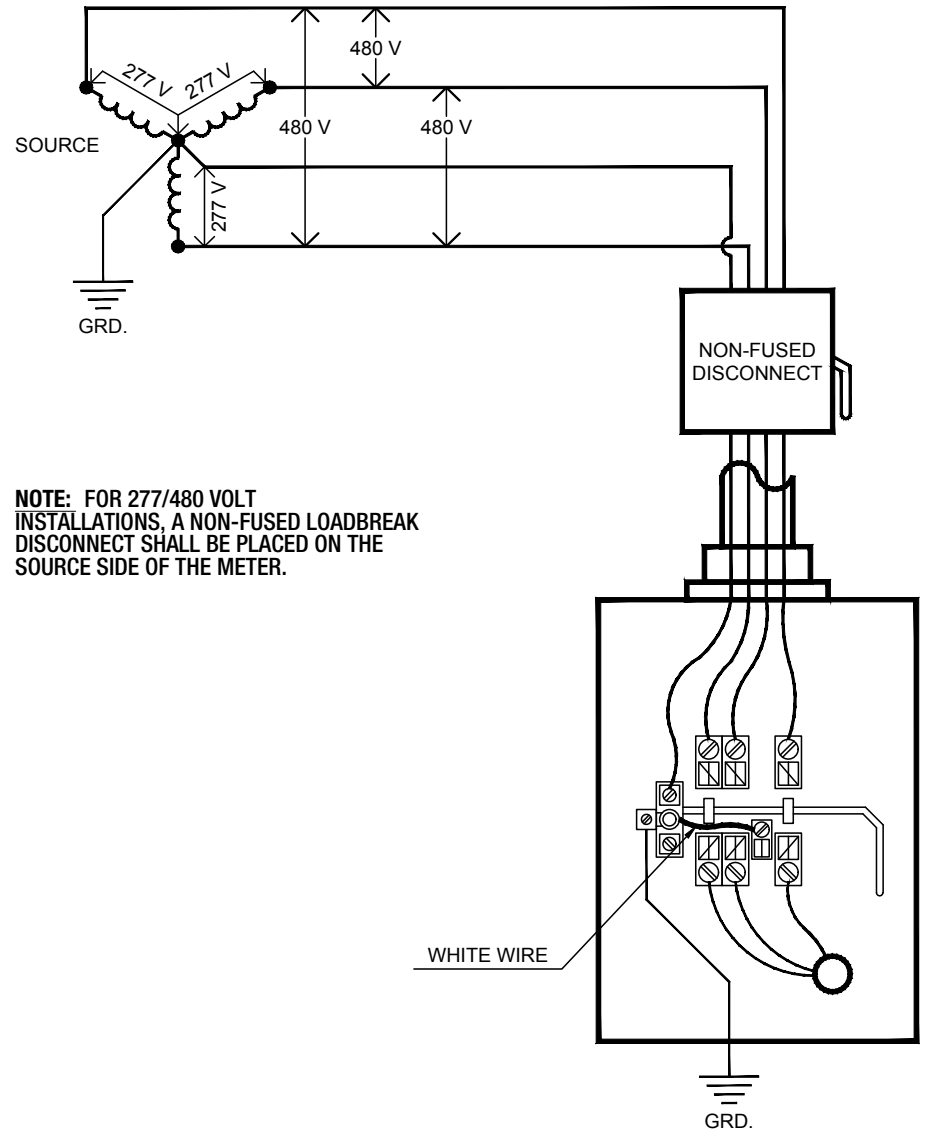

**THREE PHASE OVERHEAD 400 AMP
4-WIRE 120/240 VOLTS**

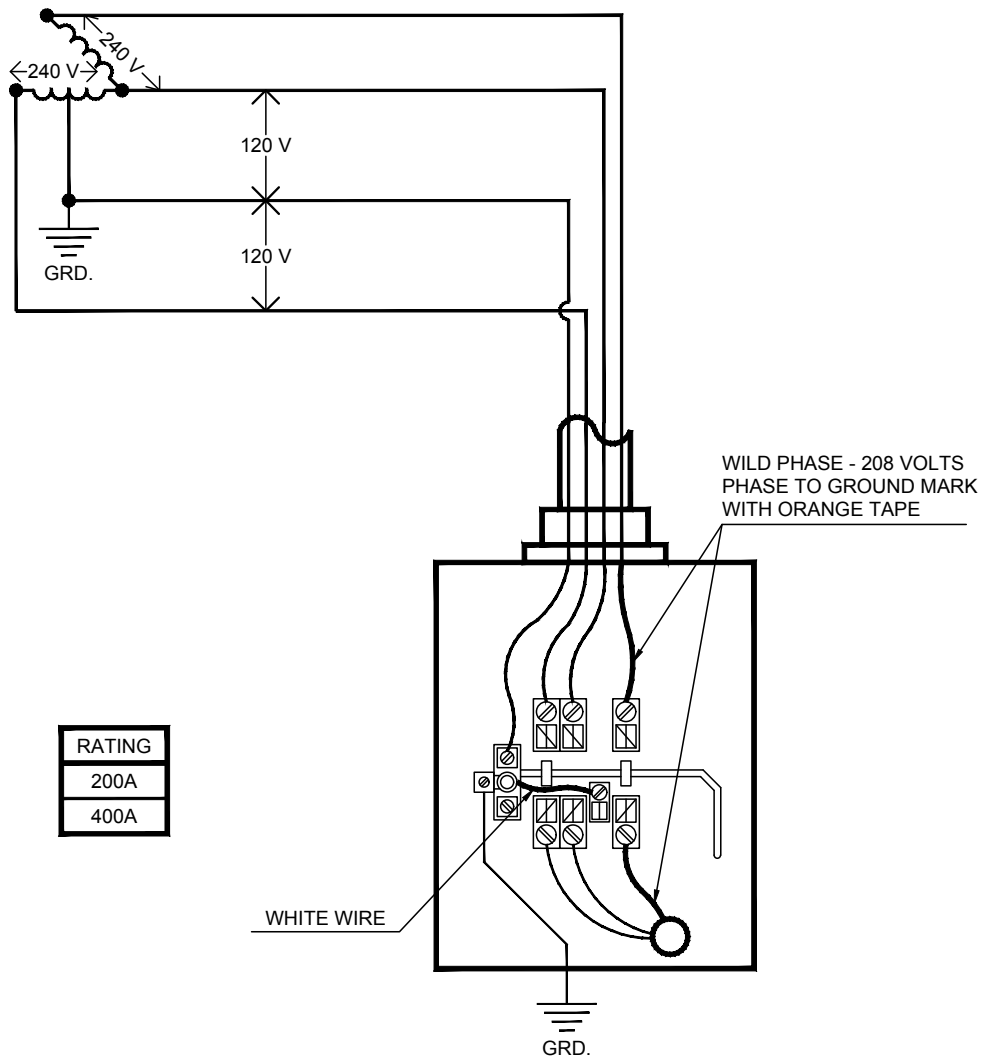

**THREE PHASE OVERHEAD 400 AMP
4-WIRE 120/208 VOLTS WYE**

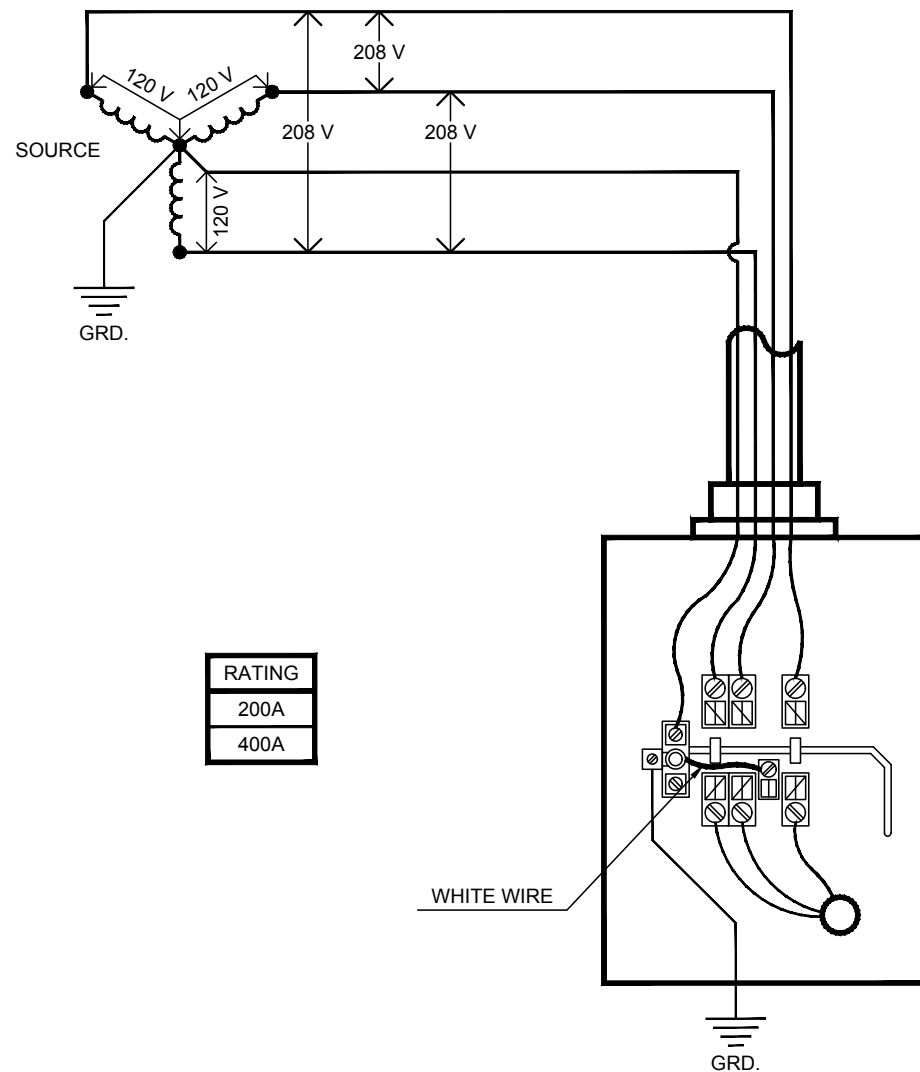

**THREE PHASE UNDERGROUND 400 AMP
4-WIRE 120/240 VOLTS**

**THREE PHASE UNDERGROUND 400 AMP
4-WIRE 120/208 VOLTS WYE**

LEFT SIDE UNDERGROUND ENTRANCE

LEFT SIDE UNDERGROUND ENTRANCE

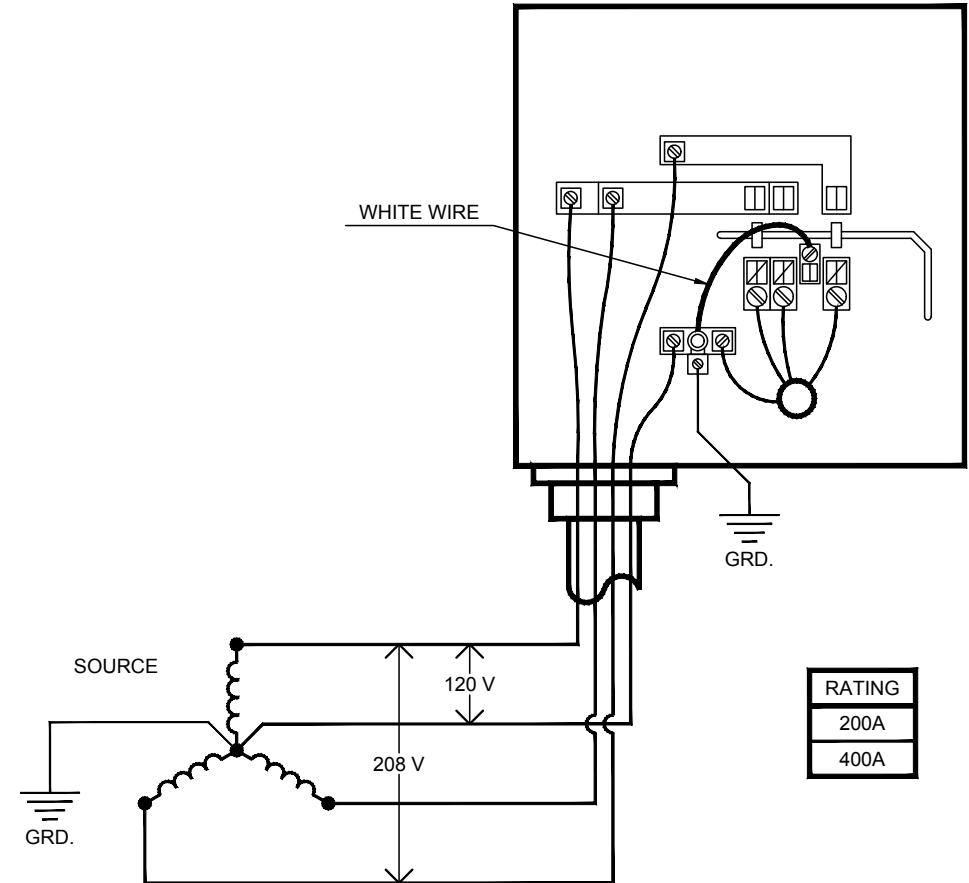
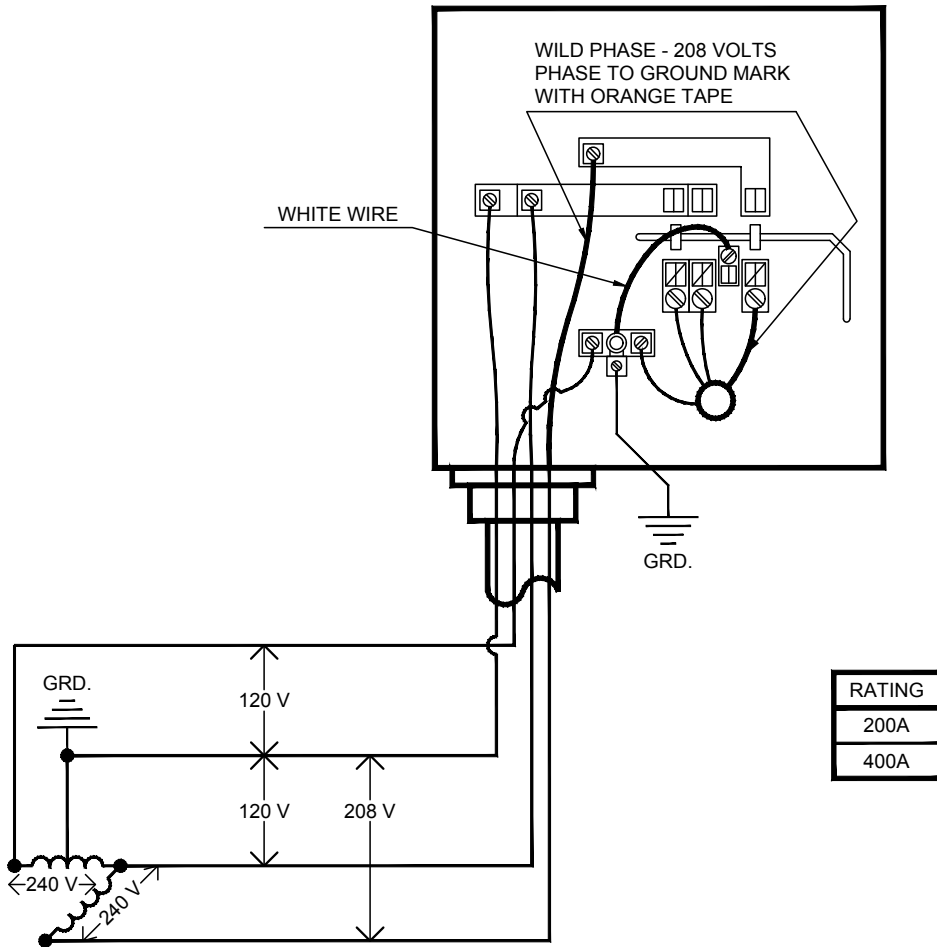

NOTE:
1. SOCKET SHALL BE SIDE WIRE, SOURCE CONNECTORS ON LEFT SIDE.
2. LOAD (CUSTOMER) WIRES SHALL NOT EXIT SOCKET THROUGH LEFT SIDE

NOTE:
1. SOCKET SHALL BE SIDE WIRE, SOURCE CONNECTORS ON LEFT SIDE.
2. LOAD (CUSTOMER) WIRES SHALL NOT EXIT SOCKET THROUGH LEFT SIDE

**THREE PHASE UNDERGROUND 400 AMP
4-WIRE 277/480 VOLTS WYE**

**CT UNDERGROUND SERVICE
3-PHASE, 4-WIRE 120/208 VOLTS
600 AMPS OR LARGER
EXTERIOR DISCONNECT**

LEFT SIDE UNDERGROUND ENTRANCE

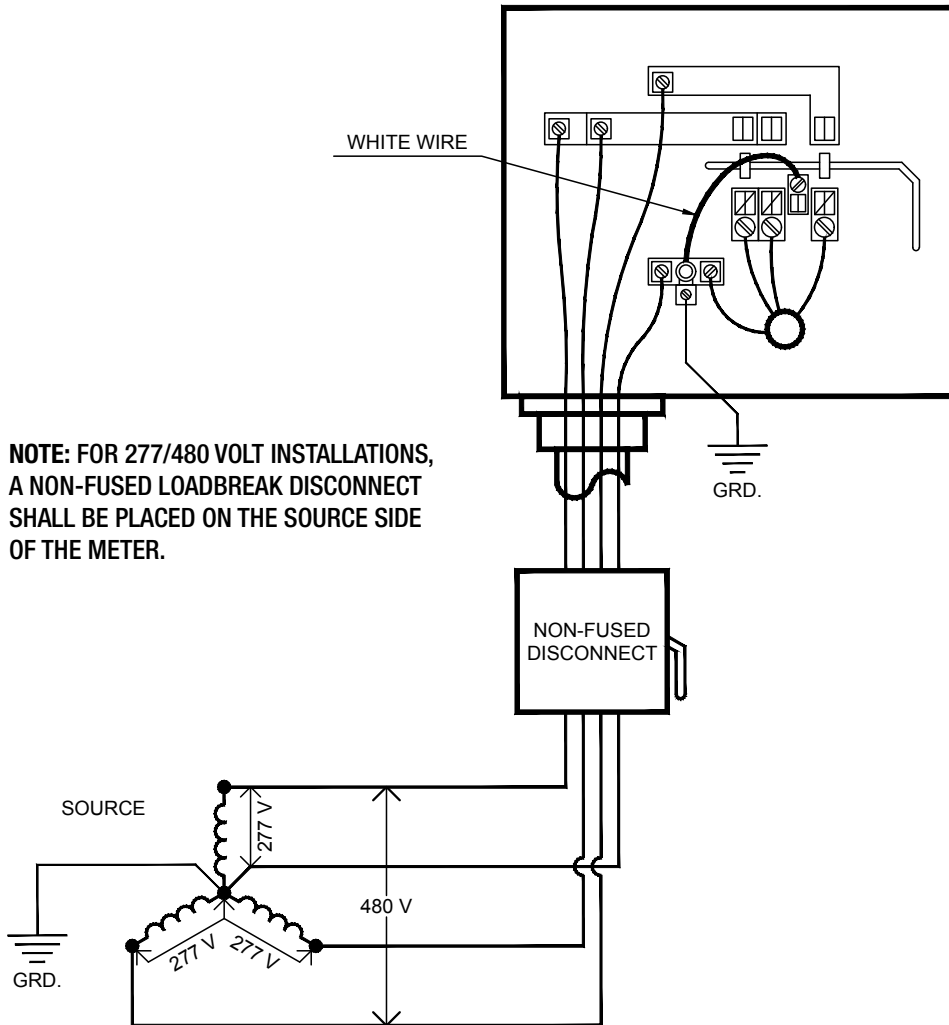

NOTE: FOR 277/480 VOLT INSTALLATIONS, A NON-FUSED LOADBREAK DISCONNECT SHALL BE PLACED ON THE SOURCE SIDE OF THE METER.

- NOTE:**
1. SOCKET SHALL BE SIDE WIRE, SOURCE CONNECTORS ON LEFT SIDE.
 2. LOAD (CUSTOMER) WIRES SHALL NOT EXIT SOCKET THROUGH LEFT SIDE

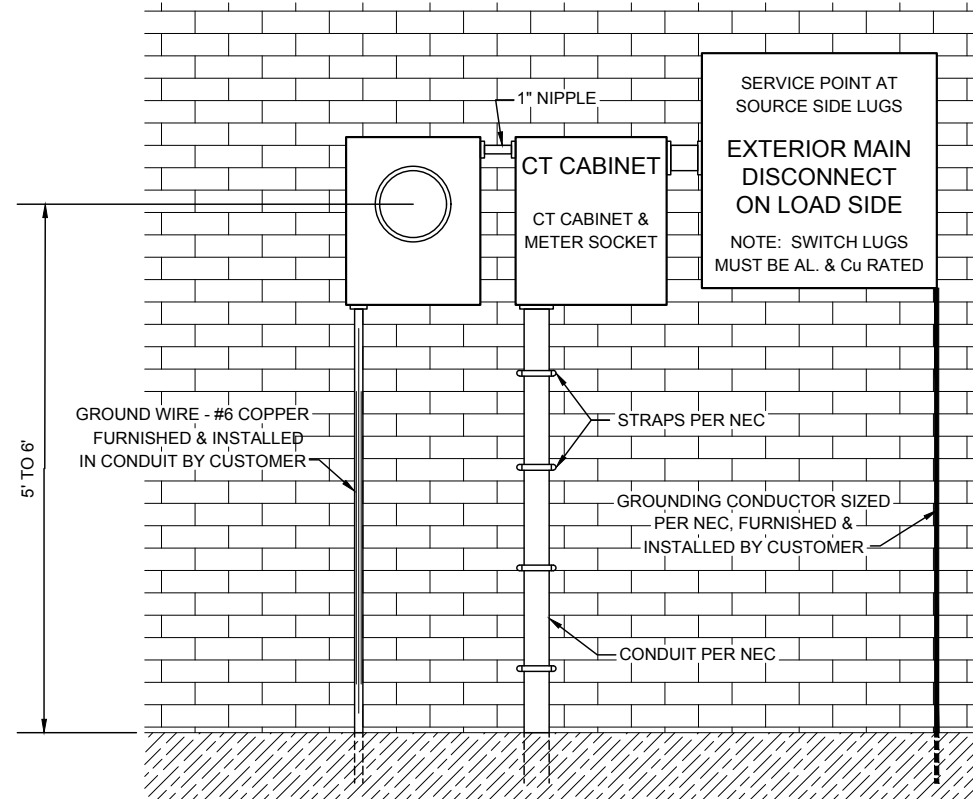

CT OVERHEAD SERVICE ENTRANCE
3-PHASE, 4-WIRE 120/208 VOLTS
600 AMPS OR LARGER
EXTERIOR DISCONNECT

CT UNDERGROUND SERVICE
3-PHASE, 4-WIRE 277/480 VOLTS
600 AMPS OR LARGER
EXTERIOR DISCONNECT

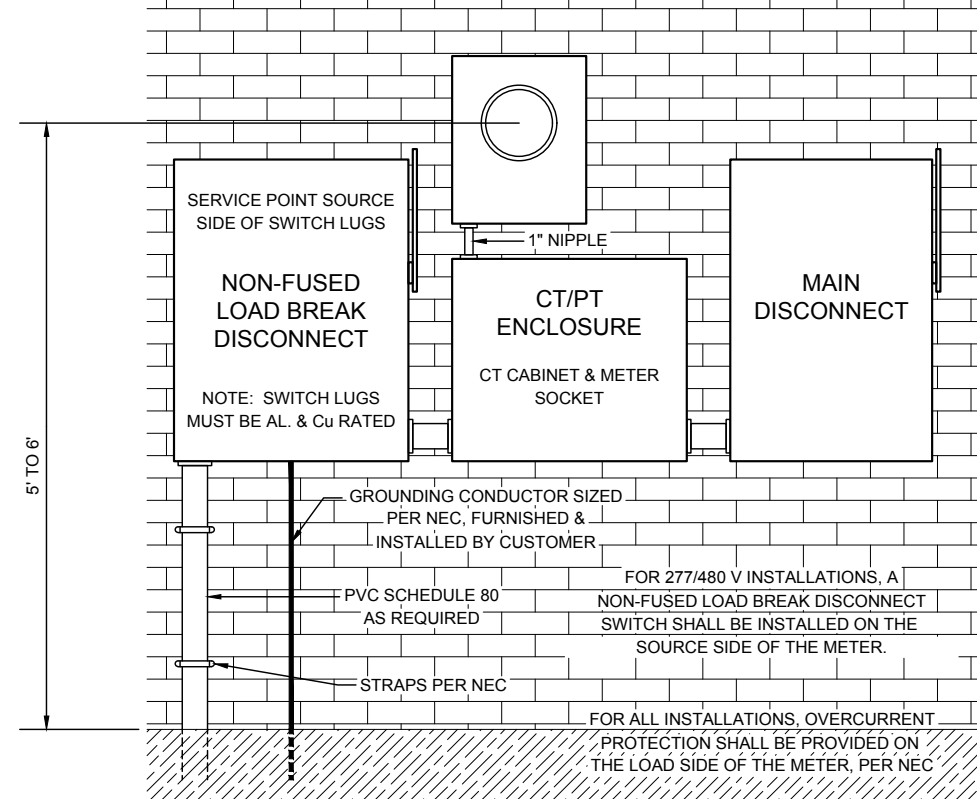
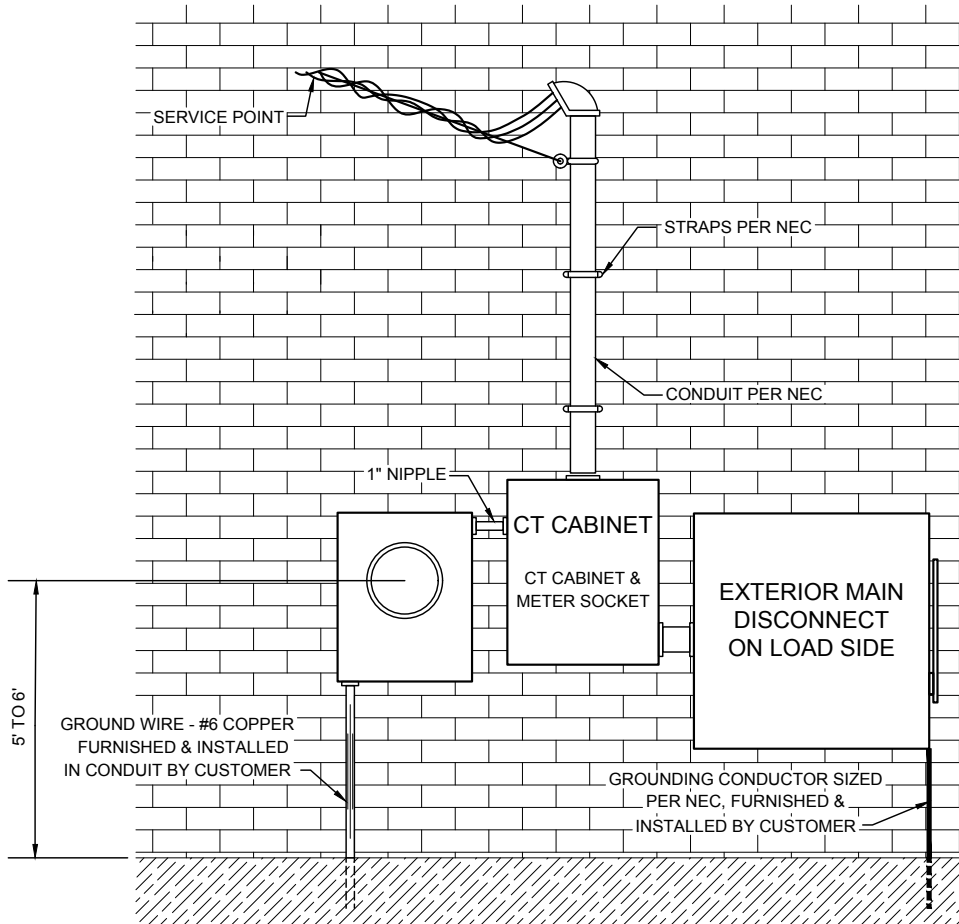

CT OVERHEAD SERVICE ENTRANCE
3-PHASE, 4-WIRE 277/480 VOLTS
600 AMPS OR LARGER
EXTERIOR DISCONNECT

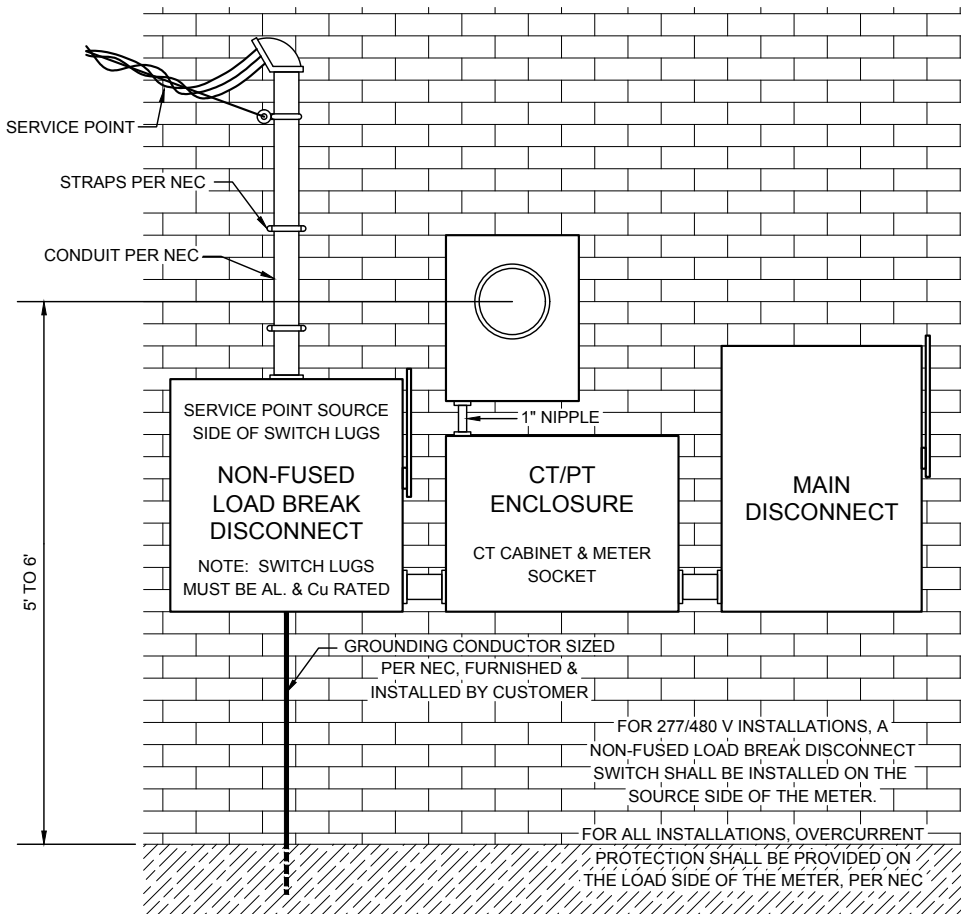



DEMCO

A Touchstone Energy[®]
Cooperative



*Providing safe, reliable, and competitively priced
energy services to co-op members since 1938.*

DEMCO.org
1-844-MyDEMCO (1-844-693-3626)

8/2022